

2910

- Exceptional signal generation capability at an economical price
- Fast frequency tuning and amplitude level settling – both <1.6ms
- Outstanding level accuracy – typically <±0.3dB
- Continuous frequency range of 400MHz–2.5GHz spans key mobile wireless frequency bands
- Intuitive, easy-to-use graphical user interface
- 40MHz modulation bandwidth using internally generated modulation
- ≥200MHz modulation bandwidth using external I/Q inputs
- Built-in waveforms for popular digital (GSM/GPRS/EDGE, cdmaOne/cdma2000 1xRTT, and WCDMA) and analog (CW, AM, FM, ΦM, noise, two-tone CW, and pulsed) signal formats
- GUI supports editing waveform files and creating new ones for GSM, GPRS, EDGE, WCDMA, cdmaOne, and cdma2000 downlink signals
- 256MB (64 mega-samples) built-in arbitrary waveform generator supports downloading waveforms generated externally
- Half-rack, 3U enclosure fits easily into both rack and benchtop system configurations
- Remote control via Ethernet, USB, and GPIB interfaces
- LXI Class C compliant
- Readily updatable software-defined radio architecture
- 3-year standard warranty

RF Vector Signal Generator



The Model 2910 RF Vector Signal Generator is the first in a series of Keithley RF instruments that sets a new price/performance standard. It's priced significantly less than instruments or systems with comparable levels of functions and performance and offers far more functionality and better performance than comparably priced equipment. While the Model 2910 offers capabilities and ranges that make it ideal for production testing of today's sophisticated mobile handsets, it also has features that make it useful for applications like testing mobile communications infrastructure, RFICs, and wireless connectivity devices. The Model 2910's exceptional testing capabilities and ease of use make it a good choice for use in mobile communications research and education settings.

When characterizing or verifying DUT performance, the speed of the RF signal generator can have a major impact on overall test throughput and, therefore, the cost of test. Higher speed also makes it possible for manufacturers to respond quickly to increased volume demands. The Model 2910 is designed to execute key tasks like frequency tuning, amplitude switching, and waveform changes significantly faster than other products available.

The Model 2910's continuous frequency range of 400MHz to 2.5GHz spans key mobile wireless bands. Digital waveforms for key tests in major cellular formats (GSM, GPRS, EDGE, WCDMA, cdmaOne, cdma2000) for testing handsets are built in, as is support for analog modulation (continuous wave, two-tone continuous wave, amplitude modulation, frequency modulation, phase modulation, pulse modulation, and noise). The 64 mega-sample Arbitrary Waveform Generator (ARB) and 40MHz modulation bandwidth support downloading a wide range of externally generated signal waveforms. A 2MHz noise bandwidth supports "quick-check" noise immunity tests on a variety of devices.

The instrument's software-defined radio architecture gives telecom manufacturers the testing flexibility needed to keep pace with changing wireless technologies, as well as fast frequency tuning, amplitude settling, and waveform switching. New signal structures and instrument features can be incorporated easily and economically with ongoing firmware updates.

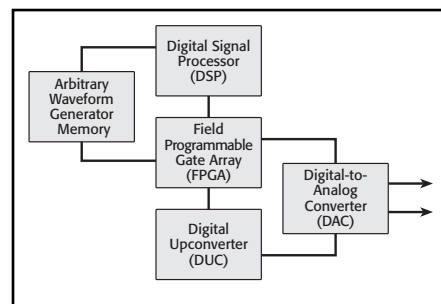

Figure 1. The Model 2910's software-defined radio architecture allows manufacturers to adapt it readily to changing test requirements.

1.888.KEITHLEY (U.S. only)

www.keithley.com

KEITHLEY

A GREATER MEASURE OF CONFIDENCE

2900

Ordering Information

2910-FRK RF Connector on Front, Configured for Rack Installation*

2910-RRK RF Connector on Rear, Configured for Rack Installation*

2910-F RF Connector on Front, Configured for Bench-top Use**

2910-R RF Connector on Rear, Configured for Bench-top Use**

* Versions configured for rack installation include rack mount kit and exclude bumpers and handle.

** Versions configured for bench-top use include bumpers and handle and exclude rack mount kit.

Options

2910-ARB 64 Mega-Sample Arbitrary Waveform Generator

2910-GSM GSM Signal Generation Personality

2910-CDMA2000 cdma2000 Signal Generation Personality

2910-WCDMA WCDMA Signal Generation Personality

2910-LPN Low Phase Noise

ACCESSORIES AVAILABLE

2910-RMK	Rack Mount Kit
2910-BENCH-KIT	Bench-Top Kit: Bumpers and Handle
2910-DCBLOCK	External DC Block
2910-ADAPTER-KIT	Cable and Adapter Accessory Kit

RF Vector Signal Generator

Higher Speed for Lower Cost of Test

A state-of-the-art digital signal processor (DSP) and high speed RF architecture provide the Model 2910's speed and help reduce RF device manufacturers' cost of test:

- **Faster tuning.** The Model 2910 can switch frequencies in less than 1.6 milliseconds for unmodulated signals and less than 1.8 milliseconds for modulated signals, which is significantly faster than many higher-priced competitive instruments.
- **Faster amplitude settling.** When changing signal amplitude levels, the Model 2910's unique RF output structure settles to specified level accuracy in less than 1.6 milliseconds for unmodulated signals and less than 1.8 milliseconds for modulated signals, which is significantly faster than most competitive instruments.
- **Highly responsive controls.** The Model 2910's high speed response to user inputs from the front panel or to programmed commands ensure fast waveform downloads and fast switching from one waveform to another, eliminating waiting times.
- **Large Arbitrary Waveform Generator.** A built-in Arbitrary Waveform Generator (AWG) with 256MB (64 mega-samples) of waveform memory allows users to have many waveforms resident in memory simultaneously. The large memory supports downloading ARB files created with external software packages like MATLAB®, Mathcad®, or other tools capable of generating I/Q waveforms. Switch quickly between waveforms—typically in less than three milliseconds.

Powerful Built-in Tools and Capabilities

The most important digital signal structures needed to produce forward link (downlink) signals for all the major cellular formats (GSM, GPRS, EDGE, WCDMA, cdmaOne, cdma2000) are already built in to the Model 2910. The intuitive graphical user interface (GUI) greatly simplifies generation of non-standard signals or modification of existing waveforms for GSM, GPRS, EDGE, WCDMA, cdmaOne, and cdma2000 forward link (downlink) signals. The large arbitrary waveform generator memory and 40MHz of modulation bandwidth extend the signal generation capability to virtually any signal with up to 40MHz of bandwidth. For applications that require even more modulation bandwidth, the Model 2910 gives users the external I/Q modulation inputs (with ≥ 200 MHz of modulation bandwidth).

The Model 2910's continuous tuning capability from 400MHz–2.5GHz covers all the key mobile communications bands, but also expands its applications far beyond the production test floor. The user-friendly GUI, easy-to-use front panel controls, and range of analog modulation capabilities make it an equally good choice for R&D applications.

Superior Signal Generation Accuracy

Digital baseband processing and optimal real-time digital reconstruction filtering allow the Model 2910 to deliver an extremely clean signal to a high performance I/Q modulator. As a result, the modulator produces signals with outstanding modulation quality. For example, the error vector magnitude (EVM) for EDGE signals is extremely low (<0.5%). This ensures precise, repeatable signals that help minimize measurement errors.

Outstanding amplitude accuracy (<0.5dB, typically <0.3dB) and linearity (<0.05dB) minimize signal level uncertainty, which minimizes measurement errors, simplifies the testing process, and allows for tighter specifications for devices under test.

APPLICATIONS

- **Mobile handset production test**
- **Handset R&D and design verification**
- **Testing mobile communications infrastructure**
- **RFIC testing**
- **Wireless connectivity testing (802.11b/g WLAN, Bluetooth)**
- **Research and education in mobile communications**

1.888.KEITHLEY (U.S. only)

www.keithley.com

KEITHLEY

A GREATER MEASURE OF CONFIDENCE

2910

RF Vector Signal Generator

Easy to Configure, Easy to Use

A variety of features combine to simplify configuring and operating Model 2910-based RF test systems:

- **Intuitive GUI.** The simplicity of the Model 2910's touch-screen graphical user interface makes it ideal for both experienced RF test engineers and novices such as students.
- **Compact size.** At just 3U (5.25 inches) high and half the width of a 19-inch rack, the Model 2910 is equally well-suited for test rack installation and benchtop use. Its compact enclosure makes it easy to pair with complementary half-rack RF instruments for a lot of testing capability in little space.
- **Choice of remote programming interfaces.** The Model 2910 offers wide connection flexibility when linking it to a system controller. Its built-in 100Base-T Ethernet and USB interfaces allow direct, high speed programming and command transfer. A GPIB interface is also included for use in legacy environments.
- **Flexible remote software tools.** A collection of tools are included with the Model 2910 to provide flexibility and simplicity to developers of remote control software applications. Programmers can develop applications directly in SCPI or make use of IVI-COM and IVI-C drivers, or a suite of LabVIEW™ building blocks.
- **LXI Class C Compliance.** The Model 2910 supports the physical, programmatic, LAN, and web portions of the emerging LAN eExtensions for Instrumentation (LXI) standard. The Model 2910 is the first RF signal generator to be certified LXI compliant.
- **Graphical Help system.** The comprehensive and easy-to-use documentation in the instrument's Help system is accessible both through the GUI and off-line, so users can refer to it while working directly with the Model 2910 or while working at their desks on their PCs.

Keithley's Growing RF Line

The Model 2910 is the latest addition to our expanding RF/wireless test offering. In fact, Keithley serves many stages within the wireless industry, starting with our automated DC/RF parametric test systems for wafer-level testing. Component manufacturers often choose Series 2400 and 2600 SourceMeter® instruments for high speed DC testing of packaged parts like RFICs. Keithley's high speed power supplies and battery/charger simulators are widely used in board-level handset testing and our THD Multimeters and Audio Analyzing DMMs are popular choices for audio test systems. We also have a broad array of RF/microwave signal routing solutions, in both standard and custom configurations, ranging from stand-alone switches and simple plug-in modules for multimeters to fully integrated turnkey solutions designed for production test applications.

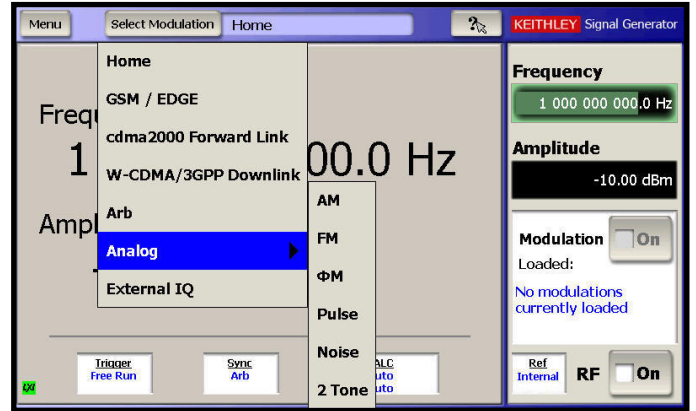

Figure 2. The Model 2910 features an intuitive GUI that simplifies selecting, creating, or editing a variety of waveforms.



Figure 3. The Model 2910 rear panel.

1.888.KEITHLEY (U.S. only)

www.keithley.com

KEITHLEY

A GREATER MEASURE OF CONFIDENCE

FREQUENCY

FREQUENCY RANGE:¹ 400MHz to 2.5GHz.

FREQUENCY SETTING RESOLUTION: 0.1Hz.

FREQUENCY SWITCHING TIME (to within 0.1ppm of final value):

≤1.6ms (modulation off), ≤1.8ms (modulation on).²

≤3.0ms (characteristic).³

FREQUENCY ACCURACY: Same as frequency reference + synth resolution term.⁴

FREQUENCY NOTES

1. Over-range operation is provided: 325MHz to 2.7GHz. Performance at frequencies below 400MHz and above 2.5GHz is not specified.
2. List mode or sweep mode. Free run or hardware trigger. ALC off. Modulation on or off.
3. To within 0.1ppm of final value. Via remote command after receipt of end-of-operation indicator (EOI). ALC off. Modulation on or off.
4. Synthesizer resolution term ≤5μHz.

INTERNAL FREQUENCY REFERENCE

AGING RATE: ≤1ppm/year.

TEMPERATURE STABILITY: ≤±0.2ppm.¹

INTERNAL FREQUENCY REFERENCE NOTES

1. Total variation relative to 23°C. 0° to 50°C ambient temperature range.

FREQUENCY REFERENCE OUTPUT

FREQUENCY: 10MHz ± reference accuracy.

AMPLITUDE INTO 50Ω: +5dBm ±3dB (characteristic).

IMPEDANCE: 50Ω (characteristic).

EXTERNAL FREQUENCY REFERENCE INPUT

FREQUENCY: 1 to 20MHz.¹

AMPLITUDE: Lock Range: -5 to +20dBm.²

IMPEDANCE: 50Ω (characteristic).

EXTERNAL FREQUENCY REFERENCE INPUT NOTES

1. On 10Hz boundaries: $F_{ref} = 1\text{MHz} + n * 10\text{Hz}$. Reference accuracy ≤±1ppm. Sine or square wave inputs acceptable.
2. For optimum phase noise 0 to +10dBm.

SPECTRAL PURITY

SSB PHASE NOISE: ≤-117 dBc/Hz (<-124 dBc/Hz characteristic).¹

SSB PHASE NOISE WITH LOW PHASE NOISE OPTION (2910-LPN):

≤-120 dBc/Hz (<-124dBc/Hz characteristic).¹

≤-113 dBc/Hz (<-117dBc/Hz characteristic).²

HARMONICS: ≤-30dBc (F_c ≤ 550MHz); ≤-40dBc (F_c ≥ 550MHz).³

NON-HARMONIC SPURIOUS: <-55dBc (<-60dBc characteristic).⁴

SPECTRAL PURITY NOTES

1. 20kHz offset at 1GHz carrier.
2. 20kHz offset at 2GHz carrier.
3. $P_{out} \leq +4\text{dBm}$.
4. Offset from carrier >10kHz. $P_{out} = 0\text{dBm}$. Modulation off.

AMPLITUDE

AMPLITUDE LEVEL RANGE (CW): -120 to +13dBm.

AMPLITUDE LEVEL RANGE (GSM): -120 to +6dBm.

AMPLITUDE LEVEL RANGE (EDGE): -120 to +6dBm.

AMPLITUDE LEVEL RANGE (cdma2000): -120 to +3dBm.¹

AMPLITUDE LEVEL RANGE (WCDMA): -120 to +4dBm.²

AMPLITUDE SETTING RESOLUTION: 0.01dB.

CW ABSOLUTE AMPLITUDE LEVEL ACCURACY:³

≤±0.5dB (+13 to -75dBm) (≤±0.3dB [+13 to -110dBm] typical).

≤±0.6dB (-76 to -110dBm) (≤±0.3dB [+13 to -110dBm] typical).

≤±1.0dB (-110 to -115dBm) (≤±0.6dB [-110 to -115dBm] typical).

RELATIVE AMPLITUDE ACCURACY (linearity): ≤±0.05dB (characteristic).⁴

AMPLITUDE REPEATABILITY: <±0.05dB.⁵

AMPLITUDE SWITCHING TIME:⁶

≤1.6ms (modulation off), ≤1.8ms (modulation on).⁷

≤3.0ms (characteristic).⁸

<2.6ms (modulation off) characteristic, <4.1ms (modulation on) characteristic.⁹

OUTPUT MATCH-VSWR: <1.35:1 (<1.25:1 characteristic).

REVERSE POWER PROTECTION: +35dBm or 10VDC.¹⁰

AMPLITUDE NOTES

1. +3dBm max. for Pilot only. +0.5dBm max. for Forward 9 channel.
2. +4dBm max. for CPICH only. -1.0dBm max. for Test Model 1 with 16 DPCH.
3. Power change over temperature: 0.015dB/°C (0° to 50°C).
4. -110dBm < P_{out} < +2dBm. Modulation off.
5. ALC mode = fast. Modulation off. P_{out} < +2dBm.
6. To within ±0.05dB of final value (to within ±0.15dB for power changes that cross P_{max} -11dB). See amplitude level range specs for P_{max} values for each modulation.
7. List mode or sweep mode. Free run or hardware trigger. ALC off.
8. Via remote command, after receipt of end-of-operation indicator (EOI). ALC off. Modulation on or off.
9. ALC = Auto (Fast for modulation off, Sample & Hold for modulation on).
10. Up to 50VDC with external DC block option (2910-DCBLOCK).

LIST AND STEP SWEEP MODES

FREQUENCY STEP/SWEEP: Start, Stop, Number of Points, Dwell Time.

AMPLITUDE STEP/SWEEP: Start, Stop, Number of Points, Dwell Time.

DWELL TIME MIN./MAX.: 0 to 1 second. Dwell time resolution = 0.1ms.

ARBITRARY LIST: List of Frequency/Amplitude/Dwell Time sets. Maximum number of sets = 1000.

ARBITRARY WAVEFORM GENERATOR

WAVEFORM MEMORY: 64 megasamples (256MB). Complex samples: 16-bit I, 16-bit Q.

MAXIMUM MODULATION BANDWIDTH (internal modulation generation): 40MHz (characteristic), <1dB flatness.

MINIMUM SEGMENT LENGTH: 100 samples.

MAXIMUM SEGMENT LENGTH: 64 megasamples.

MAXIMUM NUMBER OF SEGMENTS: 1,000.

1.888.KEITHLEY (U.S. only)

www.keithley.com

KEITHLEY

A GREATER MEASURE OF CONFIDENCE

DIGITAL MODULATION

- EVM FOR W-CDMA: <1.2% rms (typical), 1.0% rms (characteristic).¹
- RHO FOR cdma2000/cdmaOne: >0.9995 (typical), >0.9998 (characteristic).²
- EVM FOR EDGE: <0.75% rms (typical), <0.5% rms (characteristic).
- PHASE ERROR FOR GSM: <0.2° rms (typical), <0.15° rms (characteristic).
- ACP FOR W-CDMA:³ <-57dBc adjacent, <-65dBc alternate (typical).
<-59dBc adjacent, <-68dBc alternate (characteristic).
- ACP FOR cdma2000/cdmaOne:⁴ <-60dBc adjacent, <-75dBc alternate (typical).
<-61dBc adjacent, <-84dBc alternate (characteristic).
- ORFS FOR EDGE (Offsets: 200kHz/400kHz/600kHz): <-37/-63/-69dBc (characteristic).⁵
<-37/-69/-76dBc (characteristic).⁶
- ORFS FOR GSM: <-35/-65/-69dBc (characteristic).⁷
<-36/-69/-76dBc (characteristic).⁸

DIGITAL MODULATION NOTES

1. CPICH only.
2. Pilot only.
3. Adjacent: 5MHz offset. Alternate: 10MHz offset. CPICH only.
4. Adjacent: 750kHz offset. Alternate: 1.98MHz offset. Pilot only. P_{out} = 0dBm.
5. 400MHz ≤ F_{carrier} ≤ 2.5GHz. -10 ≤ P_{out} ≤ +6dBm.
6. F_{carrier} = 1GHz. P_{out} = 0dBm.
7. 400MHz ≤ F_{carrier} ≤ 2.5GHz. -10 ≤ P_{out} ≤ +6dBm.
8. F_{carrier} = 1GHz. P_{out} = 0dBm.

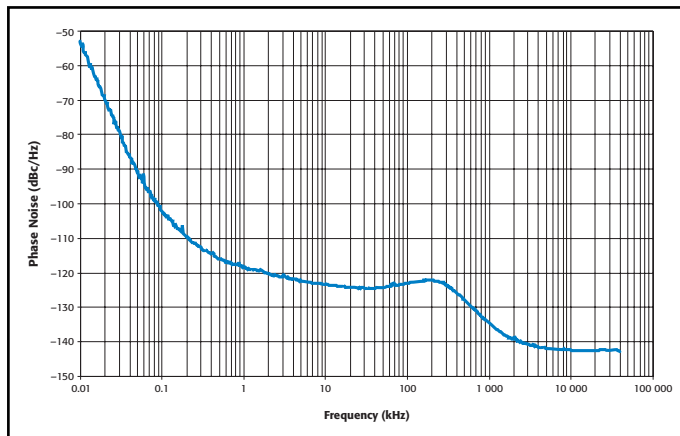

Characteristic Single Side Band Phase Noise, Carrier Frequency = 1GHz

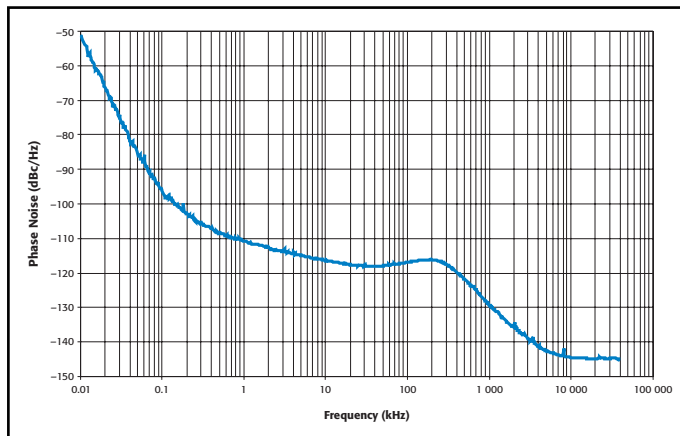

Characteristic Single Side Band Phase Noise, Carrier Frequency = 2GHz

ANALOG MODULATION

- FM MODULATION FREQUENCY RANGE: 1Hz to 100kHz.
- FM MODULATION FREQUENCY SETTING RESOLUTION: 1Hz.
- FM DEVIATION INTERNAL SINE WAVE ONLY: 0Hz to 1MHz.
- FM DISTORTION: 1.5% (characteristic).
- AM MODULATION FREQUENCY RANGE: 1Hz to 100kHz.
- AM MODULATION FREQUENCY SETTING RESOLUTION INTERNAL SINE WAVE ONLY: 1Hz.
- AM MODULATION DEPTH: 0 to 100%.
- AM DISTORTION: <1% (characteristic).
- ΦM MODULATION FREQUENCY RANGE: 1Hz to 100kHz.
- ΦM MODULATION FREQUENCY SETTING RESOLUTION: 1Hz.
- ΦM DEVIATION: 0 to 100 radians.
- ΦM DISTORTION: <1.5% (characteristic).
- PM PULSE REPETITION RATE: 1Hz to 100kHz.
- PM PULSE REPETITION RATE SETTING RESOLUTION: 1Hz.¹
- PM MINIMUM PULSE WIDTH: 1.2μs.²
- PM ON-OFF RATIO (characteristic): >50dB.³ >100dB.⁴
- PM RISE/FALL TIME (10% to 90%) (characteristic): <600ns.⁵ <2μs.⁶
- TWO-TONE CW SEPARATION SETTINGS: 2Hz to 2MHz.
- TWO-TONE CW 3rd ORDER INTERMODULATION (characteristic): -54 dBc.⁷
- TWO-TONE CW CARRIER FEEDTHROUGH (characteristic): -65dBc.⁸
- NOISE MODULATION BANDWIDTH: 1kHz to 2MHz.⁹

ANALOG MODULATION NOTES

1. Pulse period (1/Pulse Rate) will be set to nearest multiple of 0.4μs.
2. Pulse width will be set to nearest multiple of 0.4μs.
3. Pulse widths (on or off) <50μs.
4. Pulse widths ≥50μs. Valid only when Pulse Modulation is the only active modulation type.
5. Pulse widths <50μs.
6. Pulse widths ≥50μs.
7. Relative to power of desired tones. P_{out} = 0dBm.
8. Relative to amplitude of desired tones. P_{out} = 0dBm.
9. 6dB double sided.

EXTERNAL MODULATION

MAXIMUM MODULATION BANDWIDTH (external I/Q inputs): ≥200MHz (characteristic), 3dB bandwidth. Inputs applied directly to I/Q modulator. Optimal drive voltage ±0.8V. User needs to provide correction for IQ AC and DC amplitude and phase skew and offsets.

TRIGGER AND SYNCHRONIZATION INPUTS AND OUTPUTS

TRIGGER INPUT: TTL.

- Trigger Modes:
 - Free Run
 - Trigger steps in sweep/list
 - Trigger a sweep/list
 - Trigger start of arb waveform
- Trigger Source:
 - SCPI or front panel trigger
 - Rising edge of external TTL input
 - Falling edge of external TTL input
- Trigger Delay:
 - 0 to 1 second

EVEN SECOND CLOCK INPUT: TTL.
External even second clock.

SYNC OUTPUT: TTL

- Choices for generating a sync pulse:
 - Never
 - On arb waveform wrap
 - At end of each sweep in list or sweep
 - At beginning of sweep or list
 - At end of sweep or list
- Rising/Falling:
 - Sync out is on rising edge
 - Sync out is on falling edge

EVEN SECOND CLOCK OUTPUT: TTL.
External even second clock.

1.888.KEITHLEY (U.S. only)

www.keithley.com



A GREATER MEASURE OF CONFIDENCE

GENERAL**DIMENSIONS (rack-ready, without handle and bumpers):**

Height: 3U (133mm) (5.25").
Width: Half-rack (213mm) (8.4").
Depth: 464mm (18.25").
Weight: 7.82kg (17.25 lb).

HOST INTERFACES: Computer control interfaces.

IEEE-488: IEEE-488.1 compliant. Supports IEEE-488.2 common commands and status model topology.

LAN: 10/100BT Ethernet, RJ45. LXI-Class C compliant, no Auto MDIX.

USB: USB full speed.

POWER SUPPLY: 100V to 240VAC, 50–60Hz (automatically detected), 120VA max.

COOLING: Forced air. Top, bottom and side intakes and rear exhaust. For proper cooling in a rack, use Keithley 2910-RMK rack mount kit.

WARRANTY: 3 years.

EMC: Conforms to European Union Directive 89/336/EEC, EN 61326-1.

SAFETY: Conforms to European Union Directive 73/23/EEC, EN 61010-1.

ENVIRONMENT: For indoor use only.

Altitude: Maximum 2000 meters above sea level.

Specified Operating Temperature: 18°–28°C.

Operating Temperature (non-specified): 0° to 50°C.

Storage (AC power off): –25°C to 65°C, 5 to 70% RH, non-condensing.

ACCESSORIES SUPPLIED:

Cables and Connectors: Power cable.

Printed Documentation: Quick Start Guide.

Electronic Media: CD-ROMs containing 2910 System Help, utility programs and PDF files.

Specifications describe the instrument's warranted performance. Typical and characteristic values are not warranted but provide additional information regarding performance that you should expect from the Model 2910 and are provided to assist in application of the Model 2910.

Specification (Warranted Performance):

Specifications indicate performance that is warranted. All units are warranted to meet these performance specifications under the following conditions:

- Ambient operating temperature of 18° to 28°C, unless otherwise noted
- After specified warm-up time of 30 minutes.

Typical (Mean + 3 standard deviations):

Typical indicates performance that all units will meet under the following conditions:

- Ambient operating temperature of 23°C, unless otherwise noted.
- After specified warm-up time of 30 minutes.

This performance is not warranted.

Characteristic (Mean or Expected Value):

Characteristic indicates performance that a unit would be expected to exhibit under the following conditions:

- Ambient operating temperature of 18° to 28°C, unless otherwise noted.
- After specified warm-up time of 30 minutes.

This performance is not warranted.

Specifications are subject to change without notice.

All Keithley trademarks and trade names are the property of Keithley Instruments, Inc.
 All other trademarks and trade names are the property of their respective companies.

KEITHLEY

A GREATER MEASURE OF CONFIDENCE

KEITHLEY INSTRUMENTS, INC. ■ 28775 AURORA ROAD ■ CLEVELAND, OHIO 44139-1891 ■ 440-248-0400 ■ Fax: 440-248-6168 ■ 1-888-KEITHLEY ■ www.keithley.com

BELGIUM

Sint-Pieters-Leeuw
 Ph: 32-2363-0040
 Fax: 32-2363-0064
 www.keithley.nl

CHINA

Beijing
 Ph: 8610-82255010
 Fax: 8610-82255018
 www.keithley.com.cn

FINLAND

Espoo
 Ph: 358 9 88171661
 Fax: 358 9 88171662
 www.keithley.com

FRANCE

Saint-Aubin
 Ph: 33-1-6453-2020
 Fax: 33-1-60-1-77-26
 www.keithley.fr

GERMANY

Germering
 Ph: 49-89-84-93-070
 Fax: 49-89-84-93-0734
 www.keithley.de

UNITED KINGDOM

Theale
 Ph: 44-118-929-7500
 Fax: 44-118-929-7519
 www.keithley.co.uk

INDIA

Bangalore
 Ph: 91-80-2212-8027
 Fax: 91-80-2212-8005
 www.keithley.com

ITALY

Milano
 Ph: 39-02-55 38 421
 Fax: 39-02-55 38 42 28
 www.keithley.it

JAPAN

Tokyo
 Ph: 81-3-5733-7555
 Fax: 81-3-5733-7556
 www.keithley.jp

KOREA

Seoul
 Ph: 82-2-574-7778
 Fax: 82-2-574-7838
 www.keithley.co.kr

MALAYSIA

Kuala Lumpur
 Ph: 60-3-4041-0899
 Fax: 60-3-4042-0899
 www.keithley.com

NETHERLANDS

Gorinchem
 Ph: 31-1-836-35333
 Fax: 31-1-836-30821
 www.keithley.nl

SINGAPORE

Singapore
 Ph: 65-6747-9077
 Fax: 65-6747-2991
 www.keithley.com.sg

SWEDEN

Solna
 Ph: 46-8-509-04-600
 Fax: 46-8-655-26-10
 www.keithley.com

TAIWAN

Hsinchu
 Ph: 886-3-572-9077
 Fax: 886-3-572-9031
 www.keithley.com.tw